

ONKYO® SERVICE MANUAL

STEREO POWER AMPLIFIER MODEL M-502

U D	120V AC, 60Hz
U G	220V AC, 50Hz
U Q	240V AC, 50Hz
U W	120V/220V AC, 50Hz/60Hz

SAFETY-RELATED COMPONENT WARNING!!

COMPONENTS IDENTIFIED BY MARK  ON THE SCHEMATIC DIAGRAM AND IN THE PARTS LIST ARE CRITICAL FOR RISK OF FIRE AND ELECTRIC SHOCK. REPLACE THESE COMPONENTS WITH ONKYO PARTSWHOSSE PARTS NUMBERS APPEAR AS SHOWN IN THIS MANUAL.

MAKE LEAKAGE-CURRENT OR RESISTANCE MEASUREMENTS TO DETERMINE THAT EXPOSED PARTS ARE ACCEPTABLY INSULATED FROM THE SUPPLY CIRCUIT BEFORE RETURNING THE APPLIANCE TO THE CUSTOMER.

TABLE OF CONTENTS

Specifications	2
Precautions	2
Block diagram	3
Chassis-exploded view	4
Adjustment procedures	6
Packing procedures	7
IC Block diagram	8
Printed board parts list	9
Printed board view	12
Schematic diagram	
120V model	13
220V, 240V model	17
Worldwide model	21



SPECIFICATIONS

Continuous Power:	2×220 watts at 4 ohms, 1kHz (DIN)
Output:	2×145 watts at 8 ohms, 1kHz (DIN) 140 watts per channel, min. RMS, at 8 ohms, both channels driven, from 20Hz to 20kHz, with no more than 0.005% Total Harmonic Distortion
Dynamic Power Output:	2×425 watts at 2 ohms, 1kHz 2×290 watts at 4 ohms, 1kHz
Total Harmonic Distortion:	0.005% at rated power 0.005% at 1 watt output
Intermodulation Distortion:	0.004% at rated power 0.004% at 1 watt output
Frequency Response:	+0, -1.5dB at 1Hz to 100kHz
Input Sensitivity:	1.0V
Input Impedance:	20 kohms
Damping Factor:	140 (8 ohms, 1kHz)
S/N ratio:	120dB (IHF-A, Shorted)
Outputs:	SPEAKERS 1 & 2 AC OUTLET (120V models only)
Inputs:	INPUT

Power Supply:	European models: AC 220V, 50Hz Canadian models: AC 120, 60Hz U.K. & Australian models: AC 240V, 50Hz Worldwide models: AC 120V and 220V switchable, 50/60Hz
Dimensions (W×H×D):	435×186×423 mm 17-1/8"×7-5/16"×16-5/8"
Wide side panels (W×H×D):	465×187×423 mm 18-5/16"×7-3/8"×16-5/8"
Weight:	18.5 kg (40.8 lbs.)
With side panels:	20.0 kg (44.1 lbs.)

Specifications and features are subject to change without notice.

PRECAUTIONS

1. Replacing the fuses

For continued protection against risk fire, replace only with same type and same rating fuse.

CIRCUIT NO.	PART NO.	DESCRIPTION
F801,F802	252050	5A (ST-6), Primary fuse (120V,120V/220V model)
F801,F802	252075	2.5A-SE-EAK, Primary fuse (220V model)
F803,F804	252075	2.5A-SE-EAK, Primary fuse (120V/220V model)

2. Replacing the lamp

This unit uses the lamp listed below.

CIRCUIT NO.	PART NO.	DESCRIPTION
PL701, PL702	210160	PL14V150mA

3. Insulation resistance measurement (Only U.S.A. model)

Connect the insulating-resistance tester between the plug of power supply cable and the terminal GND on the back panel. Specifications; More than 10 MΩ at 500V.

4. Voltage selector (rear panel)

Worldwide models are equipped with a voltage selector to conform with local power supplies. Be sure to set this switch to match the voltage of the power supply in your area before turning the power switch on. Voltage is changed by sliding the groove in the switch with a screwdriver to the right or left. Confirm that the switch has been moved all the way to the right or left before turning the power switch on. Models without a voltage selector can only be used in areas where the power supply is the same as that of the unit.

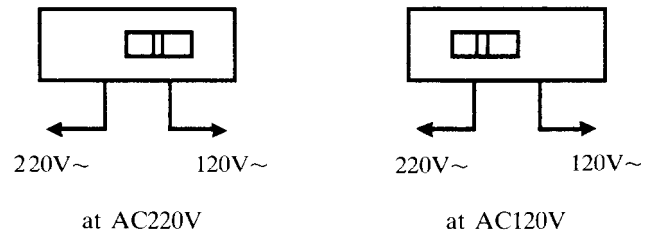

BLOCK DIAGRAM

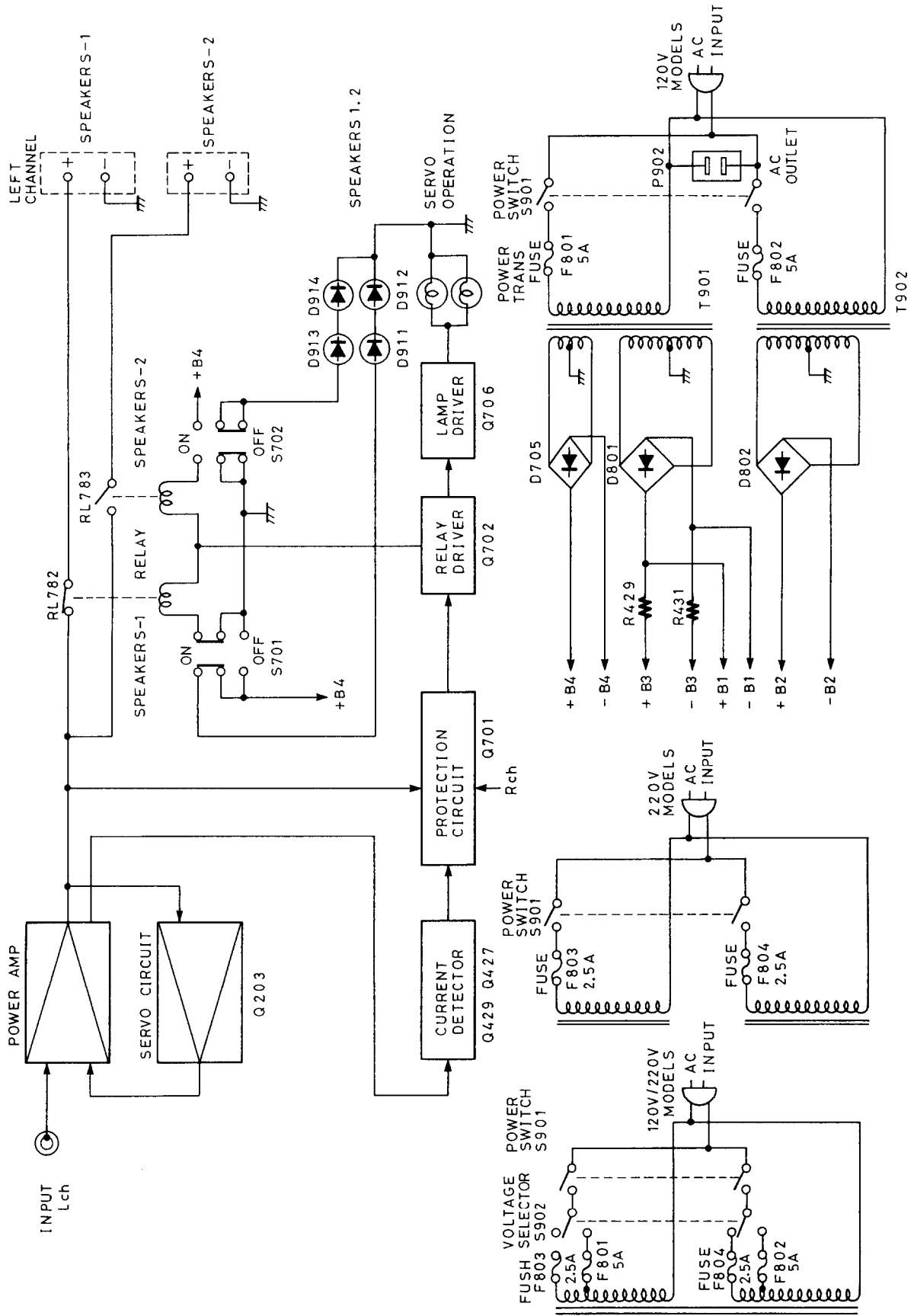

EXPLODED VIEW

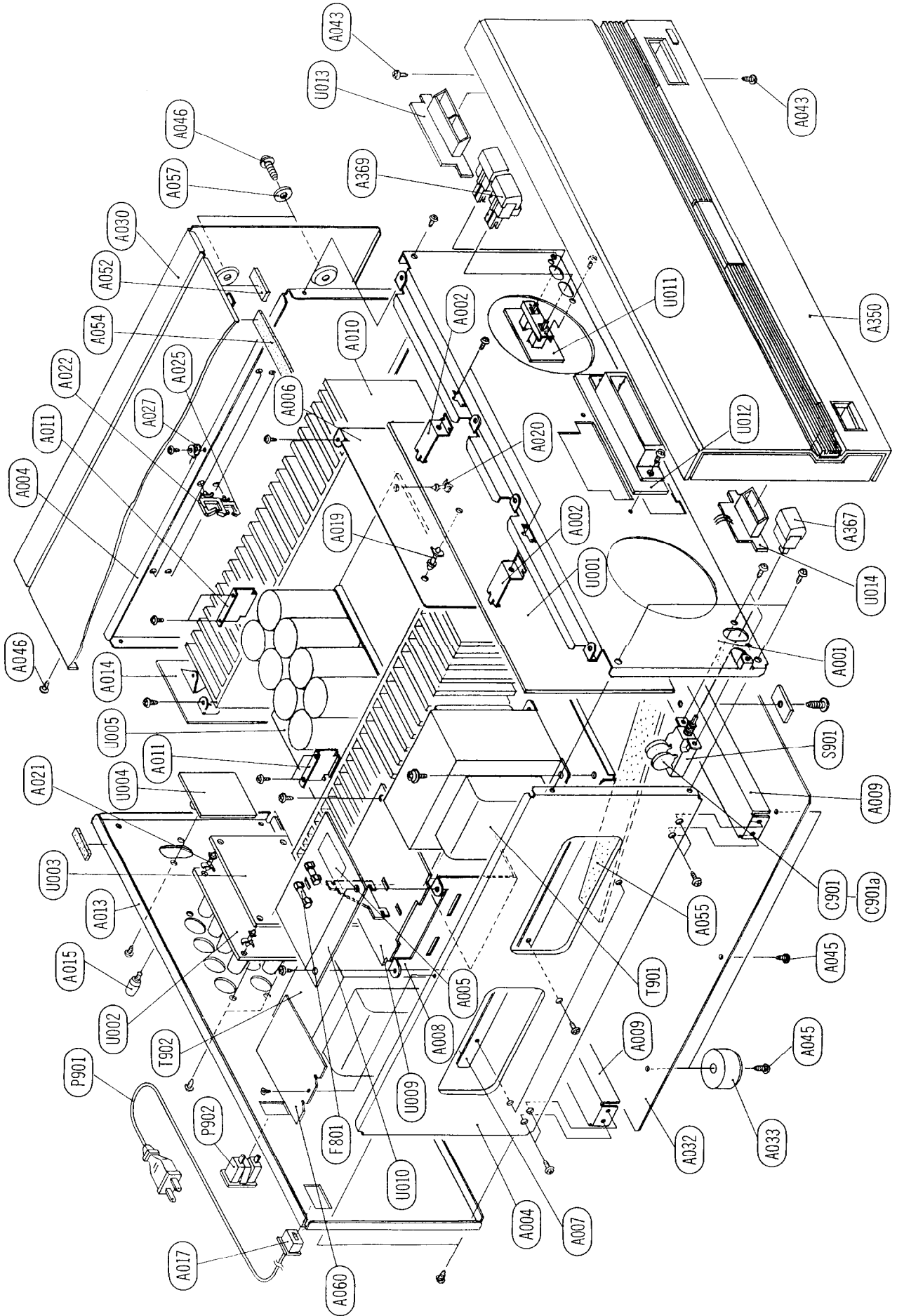

CHASSIS-EXPLODED VIEW – PARTS LIST

REF NO.	PART NO.	DESCRIPTION	REF. NO.	PART NO.	DESCRIPTION	CIRCUIT NO.	PART NO.	DESCRIPTION
A001	27110285C	Front bracket	Q449, Q450	2201653 or	2SC3856O or	U003	1A100515-1	NAETC-3315-1, Speaker terminal PC board ass'y
A002	27141064	Bracket, FPC	Q457, Q458	2201655 or	2SC3856P or	U004	1A100516-1	NAETC-3316-1, Input terminal PC Board ass'y
A004	27115204C	Side bracket	Q451, Q452	2201654	2SC3856Y, Transistors	U005	1A100520-1	NAAF-3320-1, Power amplifier circuit PC board ass'y
A005	29360626-1	Label	Q459, Q460	2201663 or	2SA1492O or	U006	1A100521-1	NAETC-3321-1, Transistor(Q443) PC board ass'y
A006	27150224	Shield plate	▲ T901	2201665 or	2SA1492Y, Transistor	U007	1A100522-1	NAETC-3322-1, Transistor(Q445) PC board ass'y
A007	27130428B	Bracket, PT		2300320	NPT-999D, Power transformer	U008	1A100523-1	NAETC-3323-1, Transistor(Q447) PC board ass'y
A008	27141266	Bracket, PC		2300321	NPT-999G, Power transformer	U009	1A100524-1	NAPS-3324-1, Power supply circuit PC board ass'y
A009	27130427	Bracket		2300322	NPT-999DG, Power transformer	U010	1A100525-1	NAETC-3325-1, Fuse PC board ass'y
A010	27160195	Radiator			[W][X]			
A011	27141068	Bracket, HE		2300323	NPT-999Q, Power transformer			
A013	27121099	Back panel			[D]			
	27121100	Back panel			[A][B]			
	27121102	Back panel		2300324	NPT-1000D, Power transformer			
	27121103	Back panel		2300325	NPT-1000G, Power transformer			
A014	27150215B	Shield plate		2300326	NPT-1000DG, Power transformer			
A015	25060041	Ground terminal			[W][X]			
A016	87644010	W4×10FBC, Washer		2300327	NPT-1000Q, Power transformer			
A017	27300750	#2271, Bushing (cord)			[A][B]			
					[W]			
					[X]			
					[D][G][X][A][B]			
					[W]			
A019	28190009	#2272, Bushing (cord)	▲ C901, C902	3500065A	0.01μF, AC400V/125V, Capacitor (IS)	U011	1A100529-1	NASW-3329-1, Speaker switch PC board ass'y
A020	27190011	Holder	▲ S901	25035381	NPS-121-L345P, Power switch	U012	1A100530-1	NADIS-3330-1, Servo operation PC board ass'y
A021	27190040	KGLS-4NS, Holder	▲ S902	25065195	NSS-1288P, Slide switch	U013	1A100531-1	NADIS-3331-1, Speaker display PC board ass'y
A022	27300243	KGLS-6S, Holder	▲ P901	253123 or	AS-UC-6#18 or			
A025	27300833	WS-2WS, Clamp	▲ P901	253136 or	AS-UC-6#18 or			
A030	28184319B	WS-2NS, Clamp	▲ P901	253140 or	AS-UC-6#18 or			
A032	28140870	Cushion, Radiator(right)	▲ P901	253146	AS-UC-6#18, Power supply cable			
A033	28140870	Cushion, Radiator(left)	▲ P902	253148 or	AS-CEE or			
A034	27170226-2	Bottom board	▲ P901	253150	AS-CEE, Power supply cable			
A035	27175153	Bottom leg ass'y	▲ P901	253131A	AS-CEE-3, Power supply cable			
A043	834430088	3TTS+8BBC, Tap-tight screw	▲ P901	253118	AS-SAA, Power supply cable			
A045	831430088	3TTW+8BBC, Tap-tight screw	▲ P901	728320 or	2-0.75BS16 BLK/GRY, Power supply cable			
A046	838440089	4TTB+8CBC, Tap-tight screw	▲ P901	728328	2-0.75BS16 BLK/GRY, Power supply cable			
A050	28140869	Cushion, Radiator(right)	▲ P902	25050290	NSCT-2P118T, AC Outlet			
A051	28140870	Cushion, Radiator(left)	▲ C901A, C902A	27300601	SB-1925, Cover (Capacitor)			
A052	28140020	T4×10×40, Cushion	▲ F801, F802	252050	5A ST-6, Primary fuse			
A054	28140695	Cushion	▲ F801, F802	252075	2.5A-SE-EAK, Primary fuse			
A055	28140761	Cushion	▲ F803, F804	252075	2.5A-SE-EAK, Primary fuse			
A057	27270202	Washer	U001	1A100510-1	NAAF-3310-1, Servo and protection circuit PC board ass'y			
A060	28175129	Insulating plate	U002	1A100514-1	NAETC-3314-1, Speaker relay circuit PC board ass'y			
A350	1A100121	Front panel ass'y						
A367	28323350A	Knob ass'y, POW						
A369	28323351A	Knob ass'y, SP						
A400	28185257	Side board, left						
A401	28185259	Side board, right						
A403	836440303	4STV+30FNBC, screw						
A404	870086	4×12BCBC, Special washer						

NOTE:
 [D]: Only 120V models
 [G]: Only 220V models
 [W]: Only 120V/220V models
 [X]: Only Military market models
 [A]: Only Australian models
 [B]: Only British models

NOTE:
 THE COMPONENTS IDENTIFIED BY MARK ▲ ARE
 CRITICAL FOR RISK OF FIRE AND ELECTRIC SHOCK.
 REPLACE ONLY WITH PARTS NUMBER SPECIFIED.

ADJUSTMENT

1. Preparation

- (1) Set the machine on the work table so that it is parallel to the table in its normal condition, with a space between the bottom of the machine and the table top of 15 mm to permit free passage of air.
- (2) There must be no load, no signal, and the VOLUME must be set to minimum level.
- (3) Before the adjustment, with the power switch OFF, there must be no heat internally.

2. Idling current adjustment

- (1) Turn ON the power switch and leave the unit as is for about 15 minutes.
- (2) Adjust the semi-fixed resistor R423 (R424) so that the voltage between terminals V CT and I ID of the printed circuit board NAAF-3320 is 15mV. (Standard value is $15 \pm 3\text{mV}$.)

Note: Semi-fixed resistor in () indicates RIGHT CHANNEL.

3. Confirmation of protective circuit operation

- (1) Check of speaker relay and muting operation
 - ① About 5 seconds after power is turned ON, relay RL782 or RL783 of PCB NAETC-3314 must go ON.
 - ② At the same time as the above relays go ON, the SERVO OPERATION lamp must light.
 - ③ When the power switch is turned OFF, immediately all relays must go OFF.
- (2) Confirmation of DC detector operation
 - ① In the no-load condition, turn ON the power switch.
 - ② When 1V DC is applied to the input terminal, the speaker relay must operate and the SERVO OPERATION lamp must go out.
 - ③ The same condition must occur for an input of -1V DC applied to the input terminal.

Note: At the time of making this test, there must be absolutely no load connected, and no short at the output terminal. (This is to avoid damage to the speaker relay contacts.)

- (3) Confirmation of current detection operation
 - ① In the no-load condition with connections made as shown in the diagram below, input a signal to the set.
 - ② Adjust the input so that the set output is 40V p-p.
 - ③ When a load of 2Ω is connected to the set, Relays RL782 or RL783 must not go OFF.
 - ④ Next, when a load of 0.33Ω is connected to the set, after the speaker relay goes ON-OFF several times, it must hold in the OFF condition.

NOTE: When there is a circuit abnormality and the protective circuit operates, the speaker relay goes ON-OFF several times repeatedly, and after several seconds, it is held in the OFF condition. Also, even after the cause of the abnormality has been eliminated, it remains held as it is. To cancel this condition turn OFF the power for several minutes.

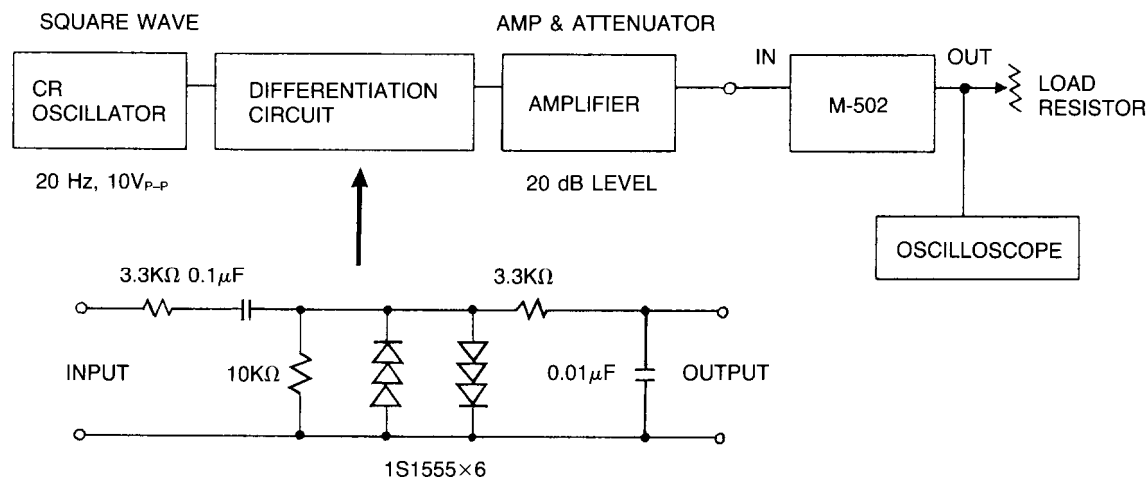

PACKING PROCEDURES

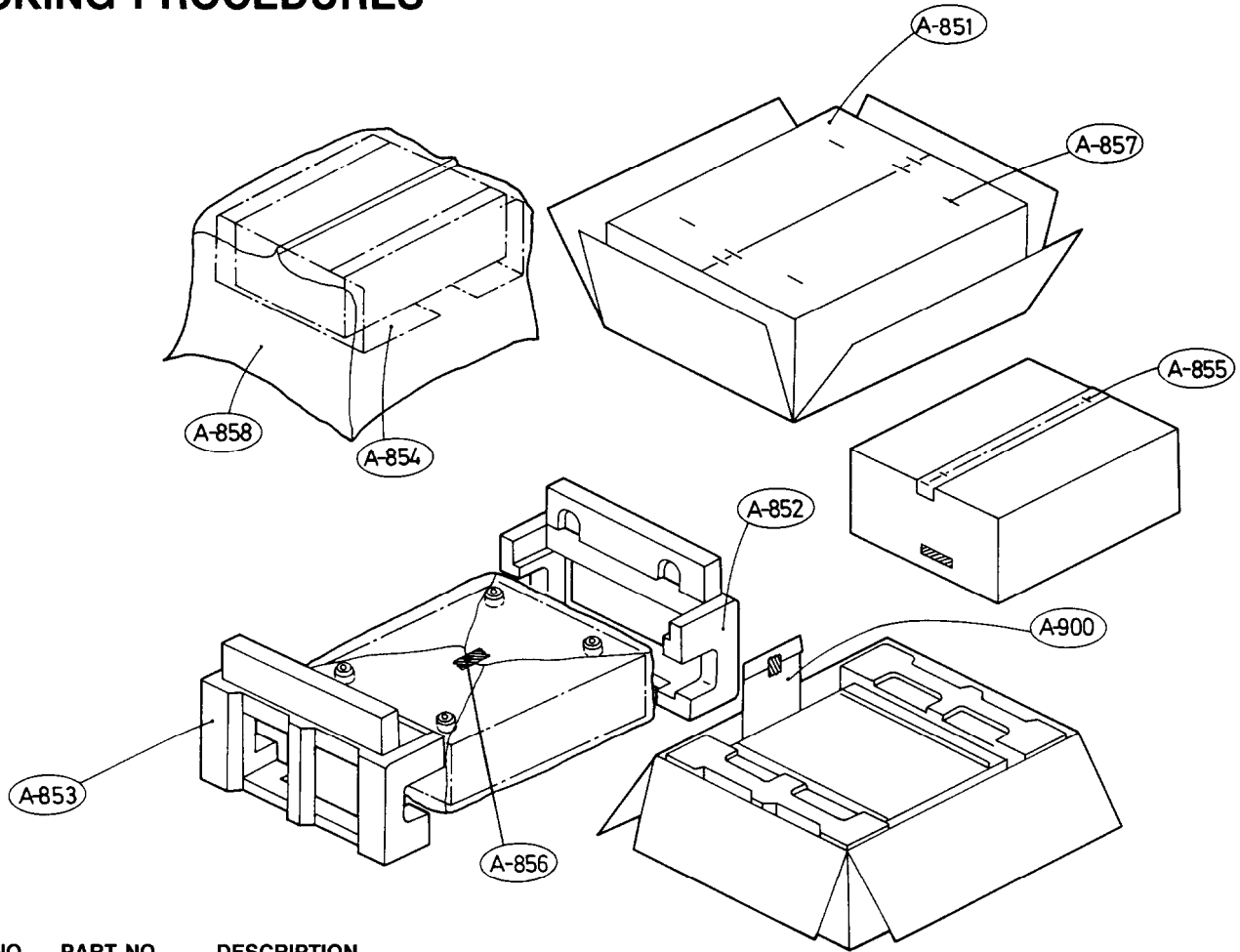

REF. NO.	PART NO.	DESCRIPTION	
A851	29051696	Master carton box	[D][G][W][A][B]
	29051733	Master carton box	[X]
A852	29091081C	Pad ass'y, L	
	29091087C	Pad ass'y, L	[X]
A853	29091084B	Pad ass'y, R	
	29091090B	Pad ass'y, R	[X]
A854	290093-1	Sheet	
	29095319	Sheet	[X]
	29095447	Sheet, P	[X]
A855	260012	Damplon tape	
A856	261504	Paper tape	
A857	282301	Sealing hook	
A858	29100038A	720×950mm, Poly-vinyl bag	
	28330072	CAP (outlet)	[X]
	29360815	Label (120)	[X]
	29380084	Caution (120)	[X]
	29360816	Label (220)	[X]
	29380085	Caution (220)	[X]

A900

Accessory bag ass'y			
29341258	Instruction manual		[D][N]
29341259	Instruction manual		[G][W][A][B]
29341299	Instruction manual		[X]
29341265	Instruction manual(I)		[G]
29365019	Warranty card		[N]
29365021	Warranty card		[X]
29358002F	Service station list		[N][X]
2010097	Connection cable		
29100006A	350×250mm, Poly-vinyl bag for accessory		
25055018	CV-K-1, Conversion plug		[W]
25055251	CV-CP, Conversion plug		[X]

NOTE

- [D]: Only 120V models
- [G]: Only 220V models
- [W]: Only 120V/220V models
- [N]: Only U.S.A. models
- [X]: Only Military market models
- [A]: Only Australian models
- [B]: Only British models

SERVICE NOTES

1. When the push switch knob is removed, the switch lock must be in the OFF condition. In particular, because it is desirable for the vertical push switch to be pulled out, care should be taken. (This is to prevent damage to the lock section.)
2. Care should be taken to avoid using excessive force when handling the speaker terminal board NAETC-3315 and the speaker relay board NAETC-3314. (This is to prevent damage to the boards.)
3. When a meter is connected to the NF loop internal circuit, the relationship of the measuring lead wire capacity and the input impedance of the meter can cause oscillation in the amplifier. When such occurs, if a 100Ω resistor is connected to the end of the meter cable, this condition can be alleviated.
4. When making amplifier measurements, if a signal is taken from the load resistor side (dummy load), because of the possibility of an output error with a large distortion measurement, the signal taken should be directly from the amplifier terminal side.

IC BLOCK DIAGRAM

TA7317P (Protective Driver)

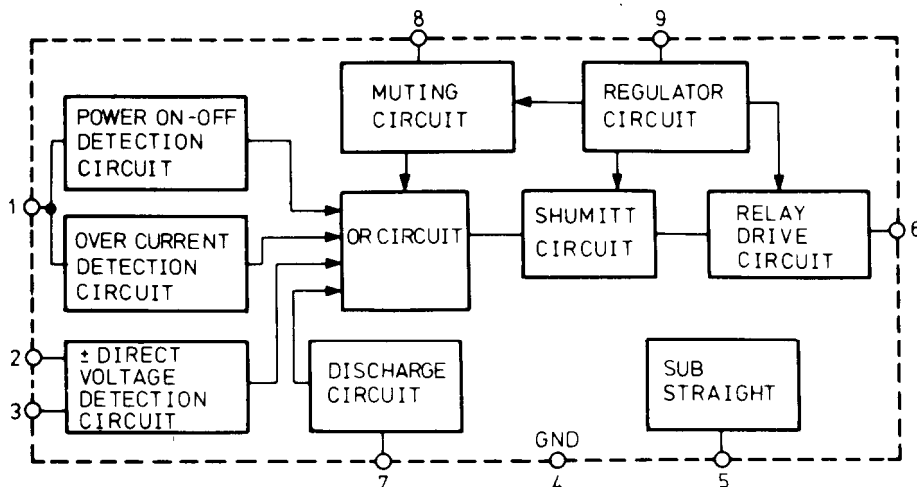

M5218L (OP Amp)

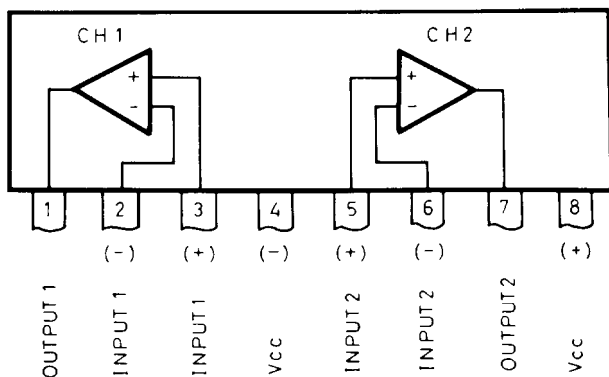

PRINTED CIRCUIT BOARD PARTS LIST

SERVO AND PROTECTION CIRCUIT PC BOARD (NAAF-3310-1) – PARTS LIST

CIRCUIT NO. PART NO. DESCRIPTION

Transistors

Q201, Q202 2212806 or 2SK389-BL or
2212807 2SK389-V
Q702 2211424 2SA817-Y
Q706 2201286 or 2SD882-P or
2201285 2SD882-Q

ICs

Q203, Q204 222652 M5218L
Q701 222584 TA7317P

Diodes

D201~D204 223163 1SS133
D205~D208 224651301 or HZ13E-B1 or
224451301 or MTZ13-A
224151301 05AZ13-X
D701 223163 1SS133
D702 224650623 or HZ6.2E-B3 or
224450623 or MTZ6.2-C or
224150623 05AZ6.2-Z
D705 223889 RC202
D706 223894 1N4002F

Capacitors

C205, C206 372125614 560pF, 50V, Styrene
C207, C208 372122214 220pF, 50V, Styrene
C215~C218 391264707 47μF, 35V, Elect. (MUSE)
C223~C226 354742219 220μF, 16V, Elect.
C701, C702 354722219 220μF, 6.3V, Elect.
C704 354742209 22μF, 16V, Elect.
C706 354784799 0.47μF, 50V, Elect.
C707 354742219 220μF, 16V, Elect.
C708, C713 354751029 1000μF, 25V, Elect
C709, C710 379121045 0.1μF, 50V, Film (DEW)

Resistors

R213, R214 441626814 680Ω, 1W, Metal oxide film
R215, R216 441722234 22KΩ, 2W, Metal oxide film
R225, R226 442522724 2.7KΩ, 1/2W, Metal oxide film
R717 442520104 1Ω, 1/2W, Metal oxide film
R722 442525114 510Ω, 1/2W, Metal oxide film
R725 441721004 10Ω, 2W, Metal oxide film
R727 442521824 1.8KΩ, 1/2W, Metal oxide film
R911, R912 442522294 0.22Ω, 1/2W, Metal oxide film

Socket ass'y

P202 2000553 NSAS-6P509
P207, P208 2000889 NSAS-6P845

Jumper sockets

JL401, JL402 25050285 NSCT-8P113
JL409 25050283 NSCT-6P111
JL601, JL604 25050280 NSCT-3P108
JL607
JL603 25050281 NSCT-4P109

SPEAKER RELAY CIRCUIT PC BOARD (NAETC-3314-1) – PARTS LIST

CIRCUIT NO. PART NO. DESCRIPTION

Diodes

D782, D783 223145 1S2076TD

Coils

L781~ L784 231015 S-0.8C

CIRCUIT NO. PART NO. DESCRIPTION

Capacitors

C783~ C786 379121245 0.12μF, 50V, Film (DEW)

Resistors

R781~ R784 441620514 5.1Ω, 1W, Metal oxide film
R785, R786 441720514 5.1Ω, 2W, Metal oxide film

Relays

RL782, RL783 25065316 NRL-2P7A-DC12-43

Jumper sockets

JL407, JL408 25050273 NSCT-9P101
JL603 25050268 NSCT-4P96

SPEAKER TERMINAL PC BOARD (NAETC-3315-1) – PARTS LIST

CIRCUIT NO. PART NO. DESCRIPTION

Terminals

P791, P792 25060120 NTM-4PDMN054

INPUT TERMINAL PC BOARD (NAETC-3316-1) – PARTS LIST

CIRCUIT NO. PART NO. DESCRIPTION

Terminal

P101 25045071 NPJ-2PDBL35

POWER AMPLIFIER CIRCUIT PC BOARD (NAAF-3320-1) – PARTS LIST

CIRCUIT NO. PART NO. DESCRIPTION

Transistors

Q401~ Q404 2211732 or 2SC1845-F or
2211733 2SC1845-E
Q405, Q406 2211792 or 2SA992-F or
2211793 2SA992-E
Q407, Q408 2211414 2SC1627-Y
Q411~ Q414 2211782 or 2SA991-F or
2211783 2SA991-E
Q415~ Q418 2211902 or 2SC1844-F or
2211903 2SC1844-E
Q421~ Q424 2211354 or 2SA949-Y or
2211353 2SA949-O
Q425, Q426 2211634 or 2SC2229-Y or
2211633 2SC2229-O
Q427, Q428 2211792 or 2SA992-F or
2211793 2SA992-E
Q429, Q430 2212560 2SC3333
Q431, Q432 2211255 2SC1815-GR
Q433, Q434 2211455 2SA1015-GR
Q435, Q436 2211634 or 2SC2229-Y or
2211633 2SC2229-O
Q437, Q438 2211354 or 2SA949-Y or
2211353 2SA949-O

Diodes

D405~D408 223163 1SS133
D409~D412 225218 LTZ-MR15, LED
D417~D420
D413~D416 223162 1SS82
D421, D422 223163 1SS133

CIRCUIT NO. PART NO. DESCRIPTION

D423,D424	223168	DA210S
D431,D432	223163	1SS133
D433,D434	223145	1S2076TD
D435~D438	22380003	1N5402F
D439~D442	223162	1SS82
D461, D462	224651002 or 224151002	HZ10E-B2 or 05AZ10-Y

Capacitors

C405~C408	354743319	330 μ F, 16V, Elect.
C413~C416	391241007	10 μ F, 16V, Elect. (MUSE)
C423, C428		
C417, C418	379121025	1000pF, 50V, Film (DEW)
C435, C436	379131045	0.1 μ F, 100V, Film (DEW)
C437, C438	379122245	0.22 μ F, 50V, Film (DEW)
C443~C446	379124735	0.047 μ F, 50V, Film (DEW)
C455~C462	3504226	6800 μ F, 80V, Elect.
C465, C466	354782299	0.22 μ F, 50V, Elect.

Resistors

R401~R404	442525614	560 Ω , 1/2W, Metal oxide film
R405, R406	442523314	330 Ω , 1/2W, Metal oxide film
R411, R412	442521614	160 Ω , 1/2W, Metal oxide film
R413, R414	441624734	47K Ω , 1W, Metal oxide film
R415, R416	442521234	12K Ω , 1/2W, Metal oxide film
R423, R424	5225076	N10HR22KBDM, Semi-fixed
R429~R432	441723324	3.3K Ω , 2W, Metal oxide film
R433~R436	442521214	120 Ω , 1/2W, Metal oxide film
R441~R444	442521024	1K Ω , 1/2W, Metal oxide film
R445~R448	442523914	390 Ω , 1/2W, Metal oxide film
R457~R460	442525104	51 Ω , 1/2W, Metal oxide film
R463, R464	442520514	5.1 Ω , 1/2W, Metal oxide film
R465, R466	441720754	7.5 Ω , 2W, Metal oxide film
R467~R470	442520224	2.2 Ω , 1/2W, Metal oxide film
R475~R478		
R479~R482	442521014	100 Ω , 1/2W, Metal oxide film
R487~R490		
R491~R494	4000080	0.47 Ω , 5W, Metal plate
R501~R504		
R505~R508	4000063	0.47 Ω , 2W, Metal plate
R513~R516		
R541, R542	442520474	4.7 Ω , 1/2W, Metal oxide film

Jumper sockets

JL403,JL404	25050267	NSCT-3P95
JL405,JL406	25050270	NSCT-6P98

Bracket

27130430	(KE)
27300826	Bus (S)
27300827	Bus (C)

TRANSISTOR PC BOARD (NAETC-3321-1) – PARTS LIST**CIRCUIT NO. PART NO. DESCRIPTION**

		Transistors
Q443,Q444	2212864 or 2212863	2SC3419-Y or 2SC3419-O
		Capacitors
C463, C464	379122235	0.022 μ F, 50V, Film (DEW)

TRANSISTOR PC BOARD (NAETC-3322-1) – PARTS LIST**CIRCUIT NO. PART NO. DESCRIPTION**

		Transistors
Q445,Q446	2201644 or 2201643	2SC3298-Y or 2SC3298-O

TRANSISTOR PC BOARD (NAETC-3323-1) – PARTS LIST**CIRCUIT NO. PART NO. DESCRIPTION**

		Transistors
Q447,Q448	2201634 or 2201633	2SA1306-Y or 2SA1306-O

POWER SUPPLY CIRCUIT PC BOARD (NAPS-3324-1) – PARTS LIST**CIRCUIT NO. PART NO. DESCRIPTION**

		Diodes
D801,D802	22380014AF	PB102F
		Capacitors
C801~C804	375103345	0.33 μ F, 125V, Film (ME)
C805, C806	375104745	0.47 μ F, 125V, Film (ME)
		Resistors
R801~R804	442522294	0.22 Ω , 1/2W, Metal oxide film
R805, R806	442527504	75 Ω , 1/2W, Metal oxide film

FUSE PC BOARD (NAETC-3325-1,NAETC-3325-1A, NAETC-3325-1B) – PARTS LIST**CIRCUIT NO. PART NO. DESCRIPTION**

		Fuse holders
F801a,F802a	250113	S-N5051
F803a,F804a	25050065	YSH403T
		Terminal
	25060092	NTM-1S33

SPEAKER SWITCH PC BOARD (NASW-3329-1) – PARTS LIST**CIRCUIT NO. PART NO. DESCRIPTION**

		Switch
S701,S702	25035591	NPS-222-L553

SERVO OPERATION PC BOARD (NADIS-3330-1) – PARTS LIST**CIRCUIT NO. PART NO. DESCRIPTION**

		Lamps
PL701, PL702	210160	PL14V150mA
		Holder
	27190640B	Lamp holder

**SPEAKER DISPLAY PC BOARD (NADIS-3331-1)
- PARTS LIST**

CIRCUIT NO.	PART NO.	DESCRIPTION
Diodes		
D911~D914	225137CG or 225137CY or 225137DG or 225137DY	SEL-2413E-CG or SEL-2413E-CY or SEL-2413E-DG or SEL-2413E-DY, LED
Holder		
	27190639	LED Holder (SP)

POWER DISPLAY PC BOARD (NADIS-3332-1) - PARTS LIST

CIRCUIT NO.	PART NO.	DESCRIPTION
Diodes		
D915, D916	225142DX2	SEL2913KDX2, LED
Jumper socket		
JL601	25050280	NSCT-3P108
Holder		
	27190638	LED Holder (POW)

NOTE

[D]: Only 120V models

[G]: Only 220V models

[W]: Only 120V/220V models

[X]: Only Military market models

[Q]: British and Australian models